

THE GREAT DESIGN DISASTER PRESENTS

# CONNECTIVE TENSION BY PAUL MATTER

FEB 18 – MAR, 2026  
VIA DELLA MOSCOVA 15  
20121 MILANO, ITALY

MONDAY TO FRIDAY  
10:00-13:00  
14:30-18:00

At The Great Design Disaster, the future does not arrive fully assembled. It comes in parts. It pivots. It hesitates. It arrives carrying stories of gravity, wire, and improbable optimism.

The Hydra works by Nikhil Paul (Paul Matter) feel like relics from a tomorrow imagined decades ago, when the future was modular, articulated, and strangely elegant. A time when light was not hidden in ceilings but performed in space, extending arms like questions, searching for connection.

The five pieces presented: ceiling lamps, wall lamps, hybrid forms, and a floor lamp, refuse clear categories. They are not designed to belong to a single surface or function, but to exist between them. Rather than obeying established lighting types, each piece proposes its own position, shaped by space, use, and circumstance.

Hydra is an organism. There is no clear beginning, no obvious end. Like light itself, it travels continuously, across ceiling, wall, and floor, ignoring architectural boundaries with gentle confidence and a mild disregard for typology. Each articulated arm shifts the object's trajectory in space, turning a fixed form into a responsive system. Slight movements generate entirely new compositions, proving that commitment is overrated and flexibility is everything.

Rather than reproducing a historical moment, the Hydra series draws from a time when technology was mechanical and expressive, when joints were visible and movement was intentional.

Each piece is made by hand using traditional metal techniques, combined with carefully controlled industrial processes. Brass is allowed to age naturally and change over time. Precision and

imperfection exist side by side, giving the works their character and physical presence.

In this exhibition, Hydra is treated less as an object and more as a character. Light steps forward from the background, calm and attentive. Some bulbs face one another, as if exchanging information. Whether they are observing, coordinating, or quietly deciding what comes next is impossible to say.

## Biography of Nikhil Paul (Paul Matter)

Born in Zambia, raised in New Delhi, and educated in Milan, Nikhil Paul founded Paul Matter in 2017. His practice explores light beyond function, operating between sculpture, design, and experience. His debut collection, Tango, established him internationally and is now considered an icon, featured in 100 Objects of Desire. His work has been exhibited at Unité d'Habitation in Marseille, Tokyo Design Week, NOMAD Circle Monaco, Salone del Mobile Milan, and PAD Art + Design in London and Paris, and is part of private collections worldwide.

## Curated by Joy Herro

Founded and curated by Joy Herro, The Great Design Disaster reflects an ongoing investigation into design as attitude, storytelling, and cultural disruption, always leaving room for humour, contradiction, and the unexpected.

THE GREAT DESIGN DISASTER  
@greatdesigndisaster  
thegreatdesigndisaster.com  
studio@thegreatdesigndisaster.com



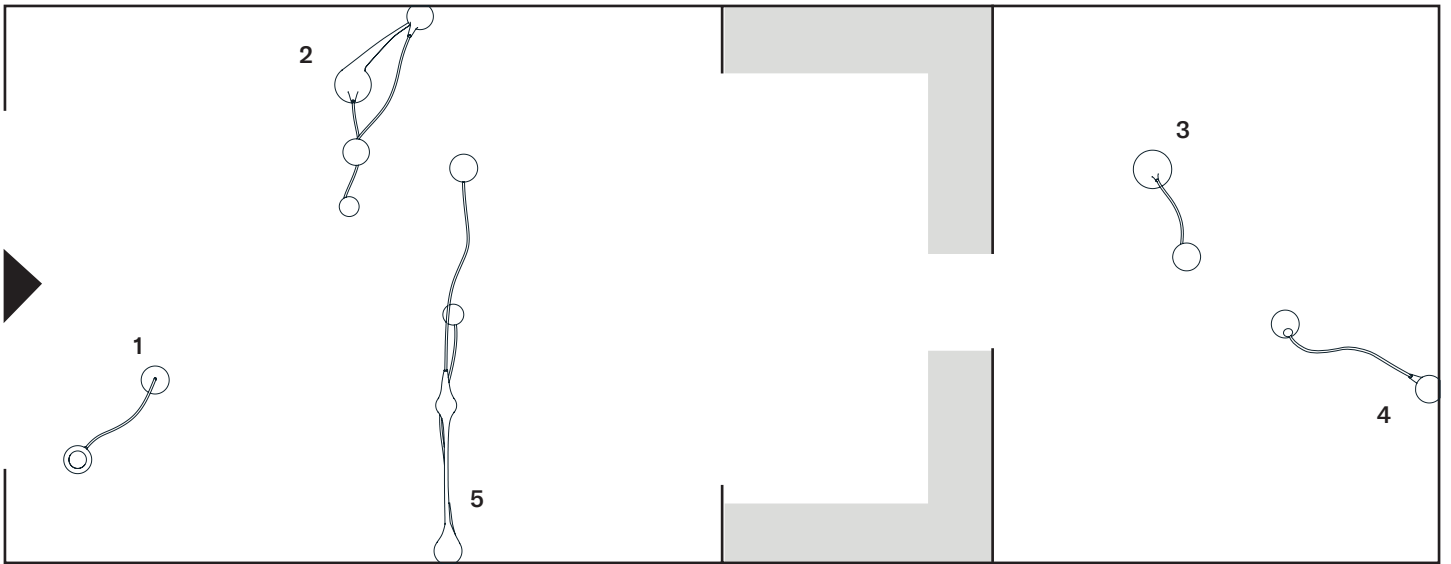

1.



**HYDRA I PENDANT**

Pendant lamp  
Paul Matter, 2026

Brass and etched glass  
185 x 32 x 100 cm  
Numbered open edition

2.



**HYDRA II FLOOR TO WALL**

Floor to wall lamp  
Paul Matter, 2026

Brass and etched glass  
282 x 75 x 161 cm  
Numbered open edition

3.

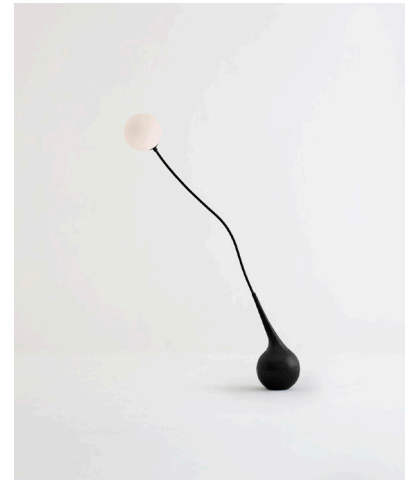

**HYDRA I FLOOR**

Floor lamp  
Paul Matter, 2026

Brass and etched glass  
200 x 28 x 92 cm  
Numbered open edition

4.



**HYDRA I WALL**

Wall lamp  
Paul Matter, 2026

Brass and etched glass  
170 x 29 x 122 cm  
Numbered open edition

5.

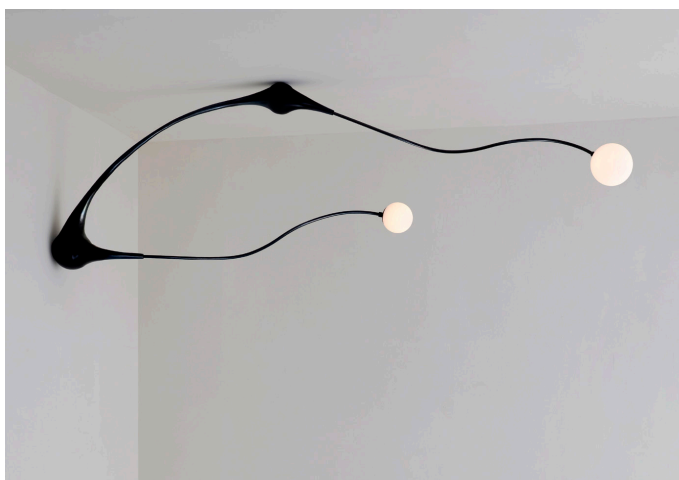

**HYDRA II WALL TO CEILING**

Wall to ceiling lamp  
Paul Matter, 2026

Brass and etched glass  
97 x 32 x 297 cm  
Numbered open edition

# HYDRA I PENDANT

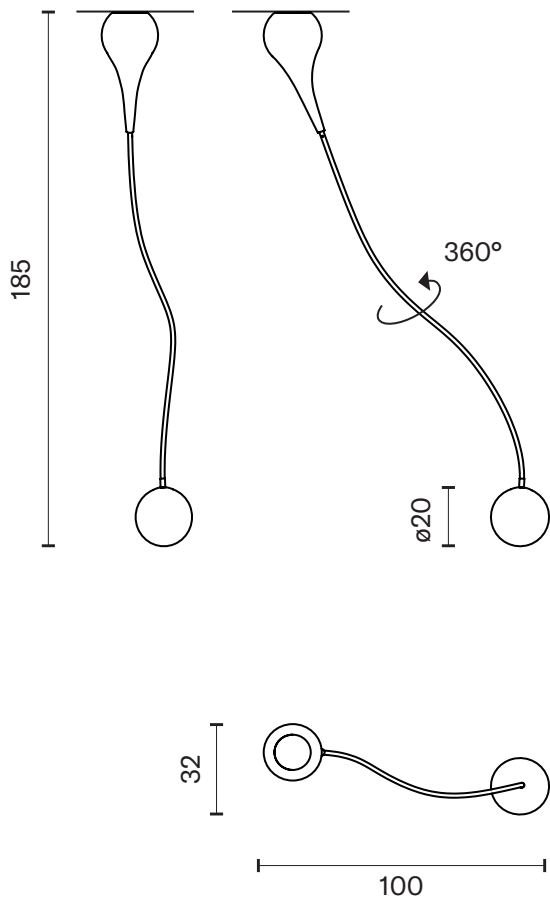

# HYDRA I PENDANT

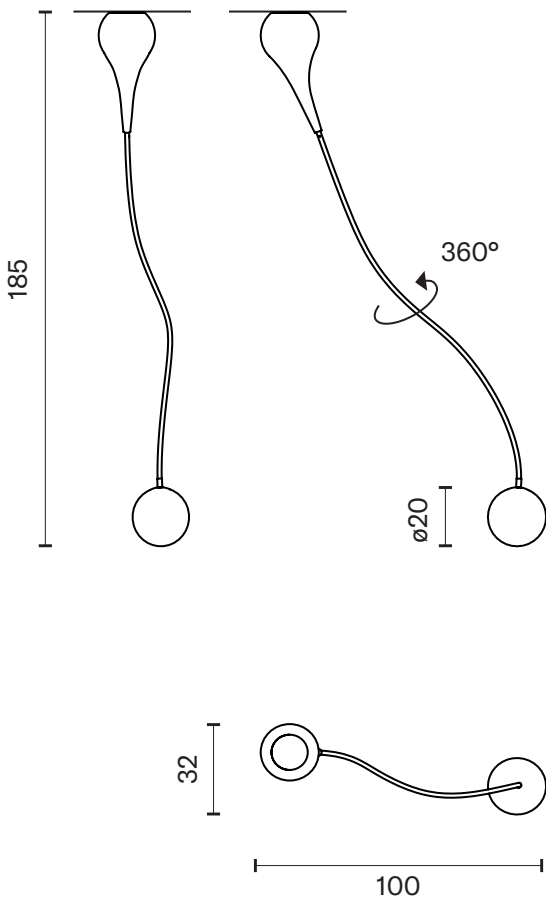

<b>TYPE</b>	Pendant lamp
<b>SIZE</b>	W:32 cm, L:100 cm, H:185 cm
<b>WEIGHT</b>	~8kg
<b>MATERIAL</b>	Brass and etched glass
<b>PRICE</b>	€ 4,725
<b>EDITION</b>	Numbered open edition
<b>VOLTAGE</b>	220-240V/110-120V
<b>BULBS INCLUDED</b>	x1 E27 / E26 base CE / UL certified 4W 220Lm 2000 - 2800K Dimmable led bulb
<b>BULB LIFE</b>	15,000 Hours
<b>DIMMING</b>	TRIAC
<b>BULB WARRANTY</b>	2 Years
<b>BOX</b>	Box 1 - 20H 20W 165L (cm) Box 2 - 25H 25W 25L (cm) Box 3 - 30H 30W 56L (cm)
<b>LEAD-TIME</b>	10 weeks Finished and assembled by hand

**NOTES**

- The arm pivots 360 degrees and can be locked at the desired orientation. Depending on the orientation of the arm, there is a variation of up to 43 (cm) / 17 (in) in the overall length and up to 25 (cm) / 10 (in) in the overall height
- Dimensions may vary by up to one inch
- Contact [info@paulmatter.com](mailto:info@paulmatter.com) for details on our list of recommended dimmers

# HYDRA II FLOOR TO WALL

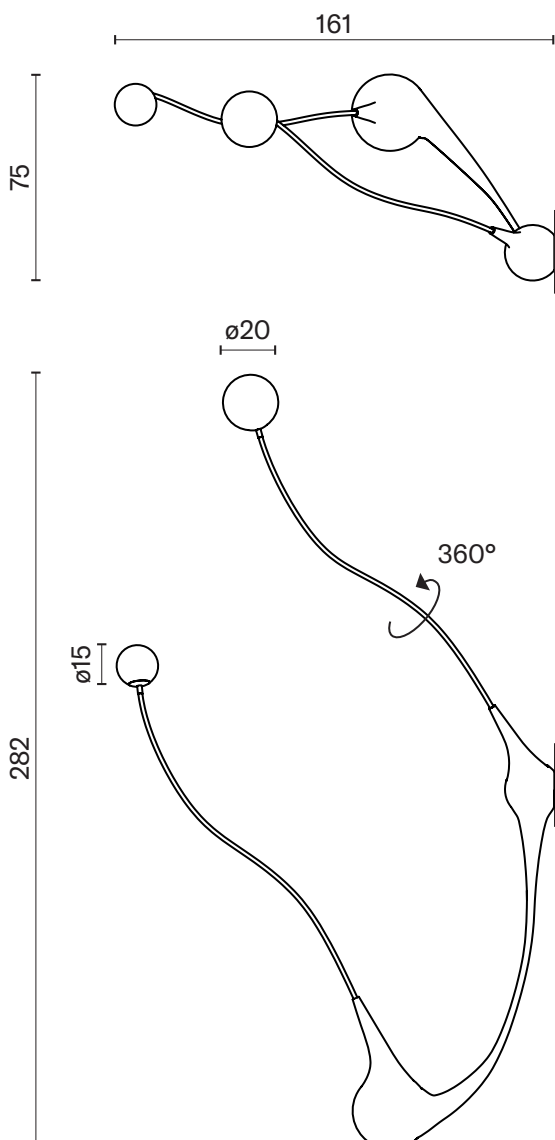

# HYDRA II FLOOR TO WALL

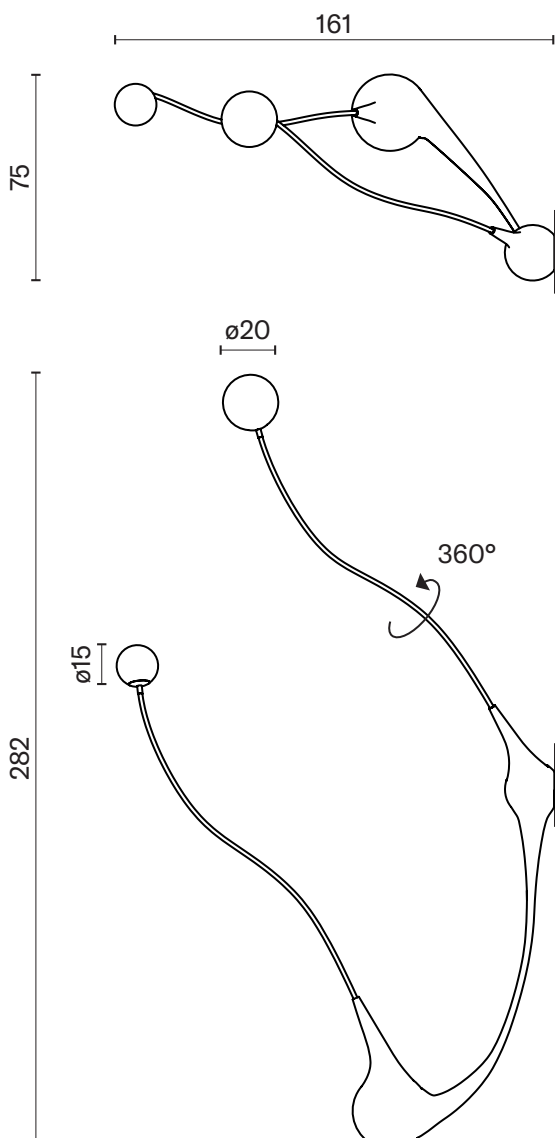

<b>TYPE</b>	Floor to wall lamp
<b>SIZE</b>	W:75 cm, L:161 cm, H:282 cm
<b>WEIGHT</b>	~30kg
<b>MATERIAL</b>	Brass and etched glass
<b>PRICE</b>	€ 11,677
<b>EDITION</b>	Numbered open edition
<b>VOLTAGE</b>	220-240V/110-120V
<b>BULBS INCLUDED</b>	x2 E27 / E26 base CE / UL certified 4W 220Lm 2000 - 2800K Dimmable led bulb
<b>BULB LIFE</b>	15,000 Hours
<b>DIMMING</b>	TRIAC
<b>BULB WARRANTY</b>	2 Years
<b>BOX</b>	48H 107W 188L (cm) ~75kg
<b>LEAD-TIME</b>	10 weeks Finished and assembled by hand

## NOTES

- The arms pivot 360 degrees individually, each covering a total diameter of 71 (cm) / 28 (in). Each arm can be locked at the desired orientation. Depending on the orientation of the arms, there is a variation of up to 47(cm) / 18 (in) in the overall length and up to 32 (cm) / 13 (in) in the overall height.
- Dimensions may vary by up to one inch
- Contact [info@paulmatter.com](mailto:info@paulmatter.com) for details on our list of recommended dimmers

# HYDRA I FLOOR

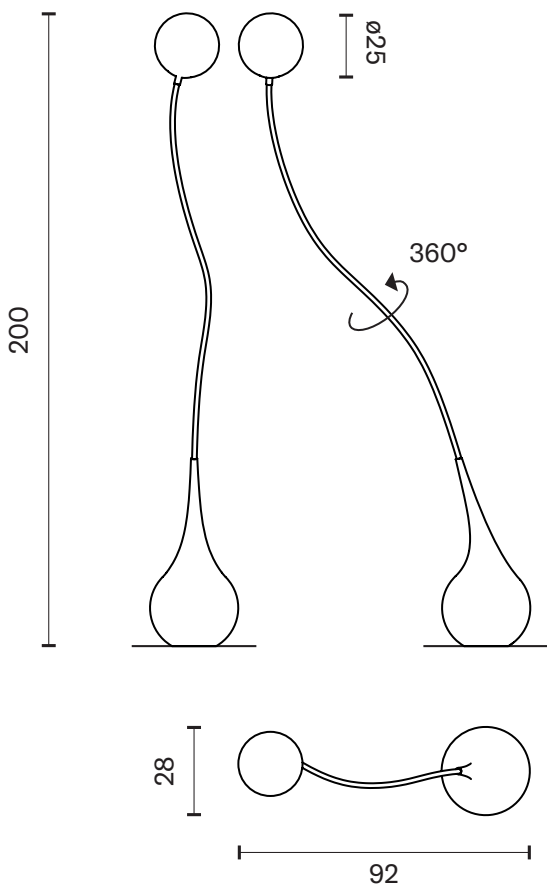

# HYDRA I FLOOR

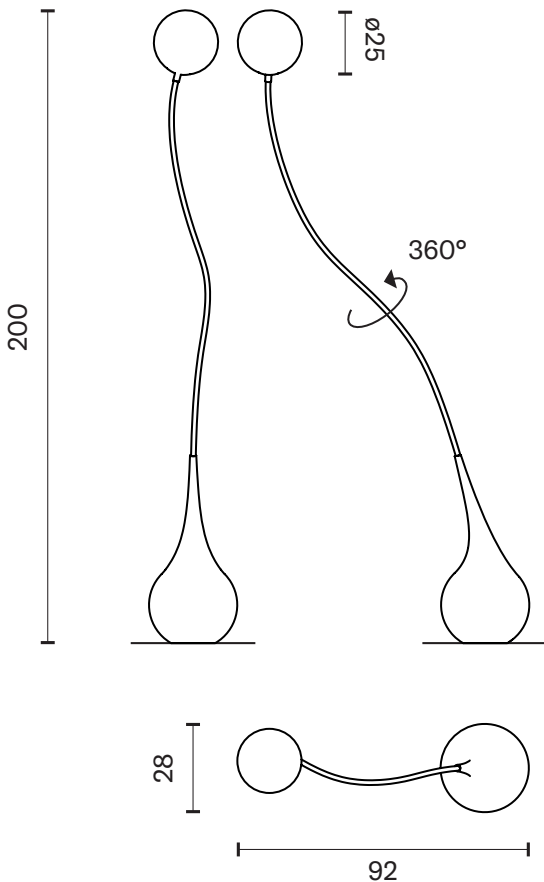

<b>TYPE</b>	Floor lamp
<b>SIZE</b>	W:28 cm, L:92 cm, H:200 cm
<b>WEIGHT</b>	~25kg
<b>MATERIAL</b>	Brass and etched glass
<b>PRICE</b>	€ 9,112
<b>EDITION</b>	Numbered open edition
<b>VOLTAGE</b>	220-240V/110-120V
<b>BULBS INCLUDED</b>	x1 E27 / E26 base CE / UL certified 4W 220Lm 2000 - 2800K Dimmable led bulb
<b>BULB LIFE</b>	15,000 Hours
<b>DIMMING</b>	TRIAC
<b>BULB WARRANTY</b>	2 Years
<b>BOX</b>	46H 43W 178L (cm) ~67kg
<b>LEAD-TIME</b>	10 weeks Finished and assembled by hand

**NOTES**

- This fixture includes a 10-foot black fabric cord. The foot switch is positioned 6 feet from the plug
- The foot switch can be replaced with a dimmer switch
- The arm pivots 360 degrees and can be locked at the desired orientation. The minimum height is 183 (cm) / 72 (in), while the tallest configuration results in an overall height (OAH) of 201 (cm) / 79 (in)
- Dimensions may vary by up to one inch
- Contact [info@paulmatter.com](mailto:info@paulmatter.com) for details on our list of recommended dimmers

HYDRA I WALL

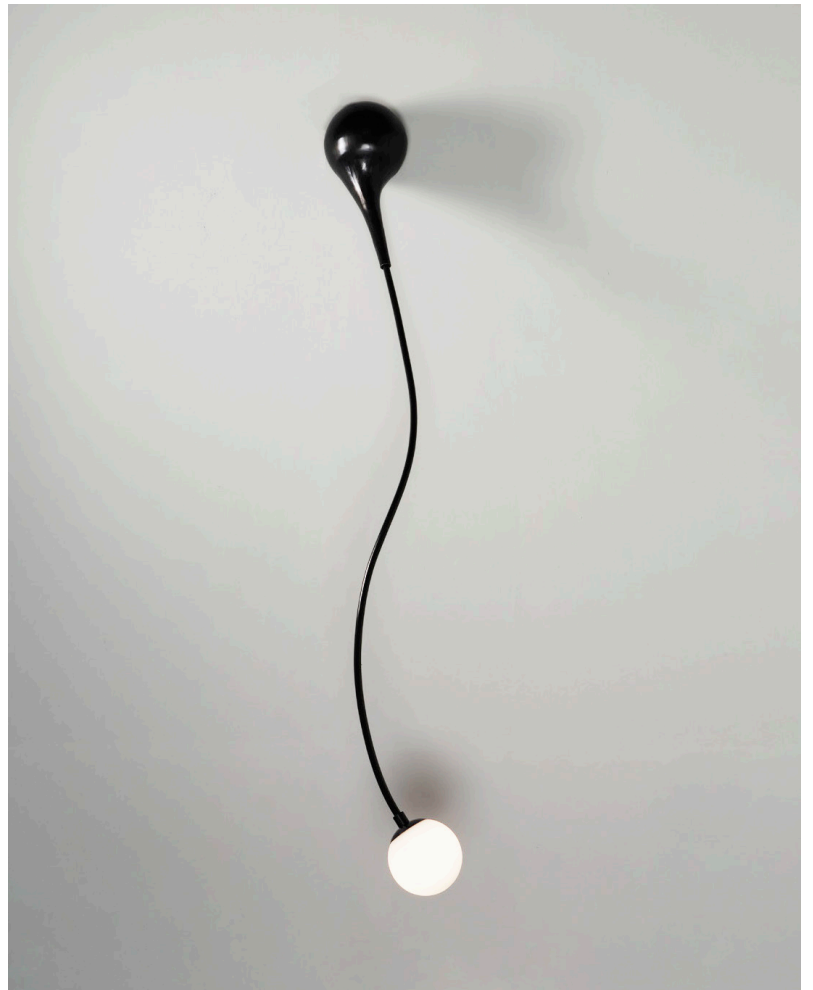
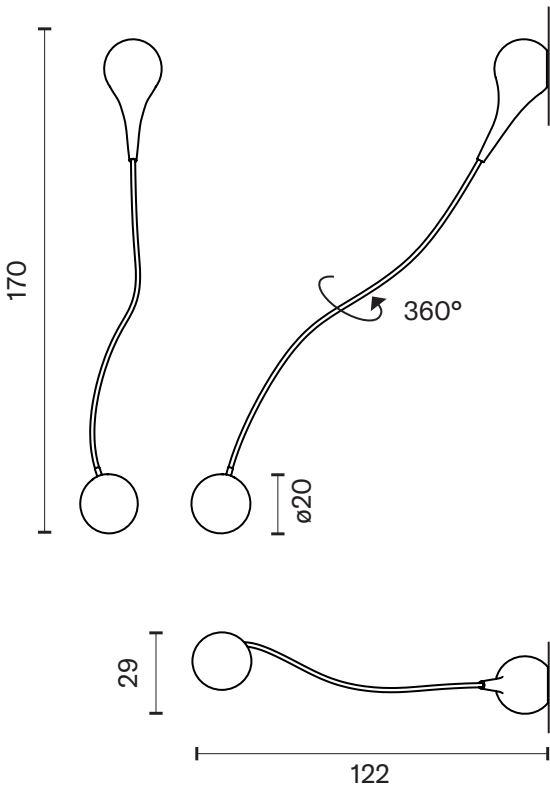

# HYDRA I WALL

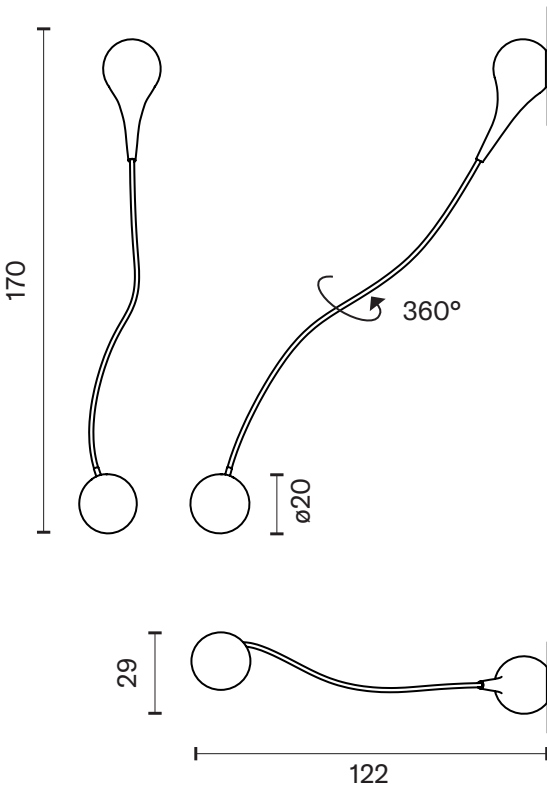

<b>TYPE</b>	Wall lamp
<b>SIZE</b>	W:29 cm, L:122 cm, H:170 cm
<b>WEIGHT</b>	~7kg
<b>MATERIAL</b>	Brass and etched glass
<b>PRICE</b>	€ 4,725
<b>EDITION</b>	Numbered open edition
<b>VOLTAGE</b>	220-240V/110-120V
<b>BULBS INCLUDED</b>	x1 E27 / E26 base CE / UL certified 4W 220Lm 2000 - 2800K Dimmable led bulb
<b>BULB LIFE</b>	15,000 Hours
<b>DIMMING</b>	TRIAC
<b>BULB WARRANTY</b>	2 Years
<b>CUSTOM LENGTHS</b>	Minimum length 182 (cm) Base price includes up to 308 (cm) Additional length at 10 USD/10 EURO x inch
<b>BOX</b>	Box 1 - 20H 20W 165L (cm) Box 2 - 30H 30W 56L (cm) Box 3 - 25H 25W 25L (cm) ~ 11kg Subject to change as per specified drop length
<b>LEAD-TIME</b>	10 weeks Finished and assembled by hand

**NOTES**

- The arm pivots 360 degrees and can be locked at the desired orientation. Depending on the orientation of the arm, there is a variation of up to 43 (cm) / 17 (in) in the overall length and up to 25 (cm) / 10 (in) in the overall height
- Dimensions may vary by up to one inch
- Contact [info@paulmatter.com](mailto:info@paulmatter.com) for details on our list of recommended dimmers

HYDRA II WALL TO CEILING

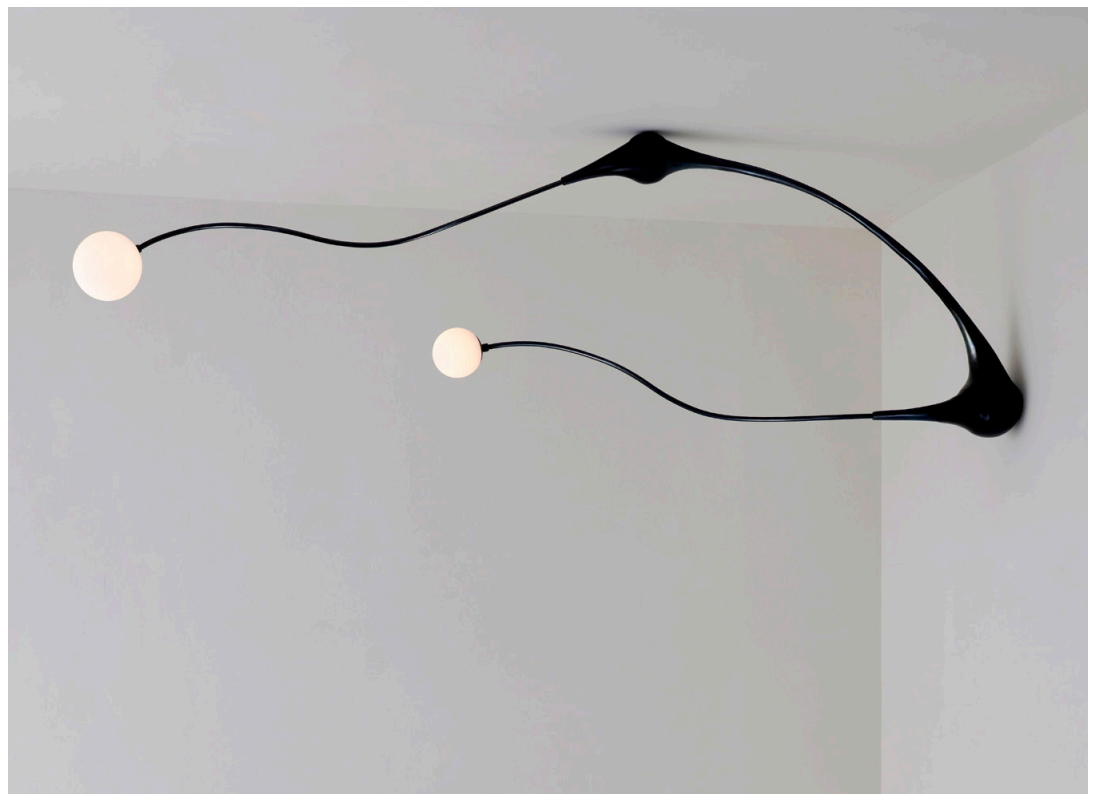
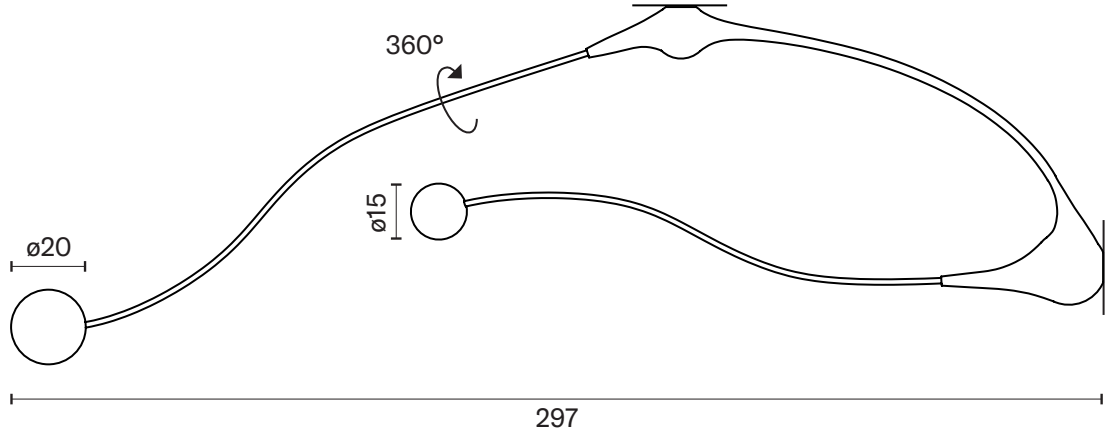
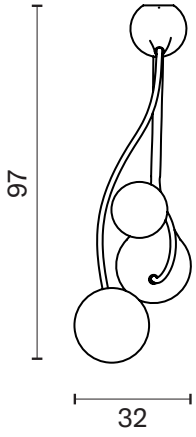

## HYDRA II WALL TO CEILING

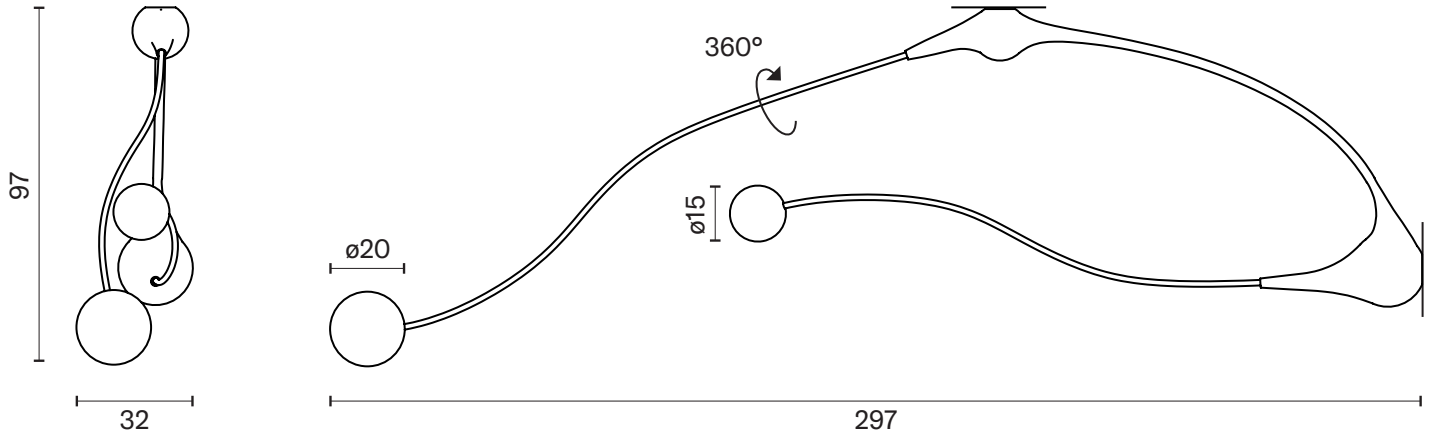

<b>TYPE</b>	Wall to ceiling lamp
<b>SIZE</b>	W:32 cm, L:297 cm, H:97 cm
<b>WEIGHT</b>	~15kg
<b>MATERIAL</b>	Brass and etched glass
<b>PRICE</b>	€ 11,677
<b>EDITION</b>	Numbered open edition
<b>VOLTAGE</b>	220-240V/110-120V
<b>BULBS INCLUDED</b>	x2 E27 / E26 base CE / UL certified 4W 220Lm 2000 - 2800K Dimmable led bulb
<b>BULB LIFE</b>	15,000 Hours
<b>DIMMING</b>	TRIAC
<b>BULB WARRANTY</b>	2 Years
<b>BOX</b>	48H 107W 188L (cm) ~45kg
<b>LEAD-TIME</b>	10 weeks Finished and assembled by hand

### NOTES

- The arms pivot 360 degrees individually, each covering a total diameter of 71 (cm) / 28 (in). Each arm can be locked at the desired orientation. Depending on the orientation of the arms, there is a variation of up to 16 (cm) / 6 (in) in the overall length and up to 26 (cm) / 10 (in) in the overall height
- Dimensions may vary by up to one inch
- Contact [info@paulmatter.com](mailto:info@paulmatter.com) for details on our list of recommended dimmers

Set variation of Hydra I Wall - Hydra I Floor - Hydra I Pendant



Set variation of Hydra I Wall - Hydra I Pendant - Hydra I floor - Hydra II Wall to ceiling - Hydra II Floor to Wall

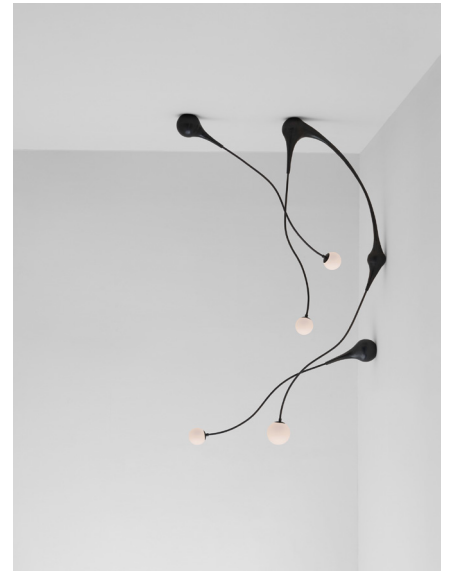

Set variation of Hydra II Floor to Wall - Hydra II Wall to ceiling



